

TEAXY Series electronic Slide

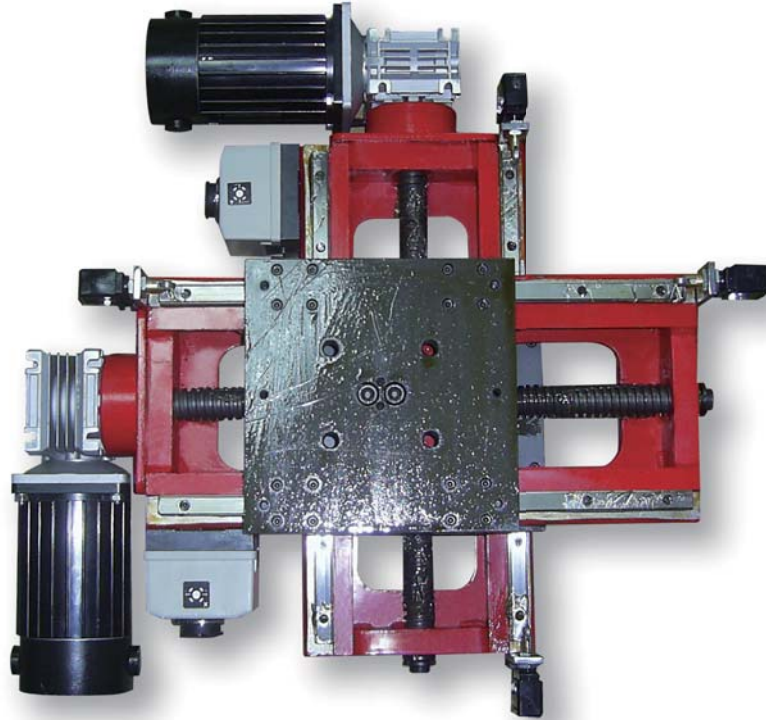

2009.Feb.



TEA-XY1 Electronic Slide

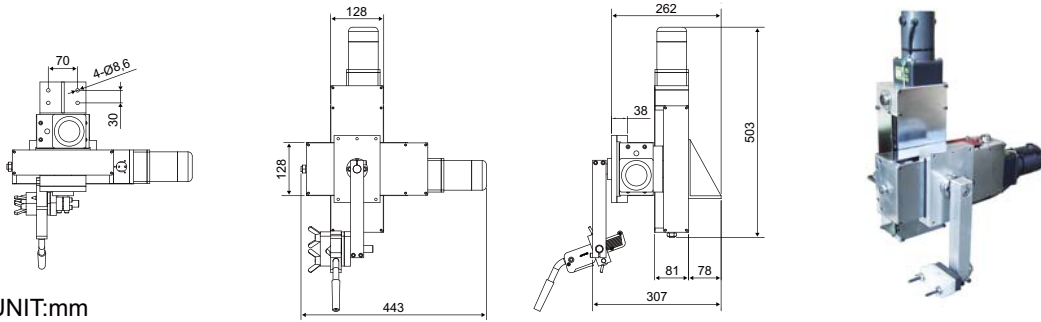

UNIT:mm

Power	AC 110V / 4A / 60Hz / 1Ø
Load	6Kgs.
LoadLevel stroke (X axle)	150mm.
Level speed	150mm/min
Vertical stroke (Y axle)	150mm.
Vertical speed	150mm/min
Control operation	Rocker



TEA-XY2 Electronic Slide

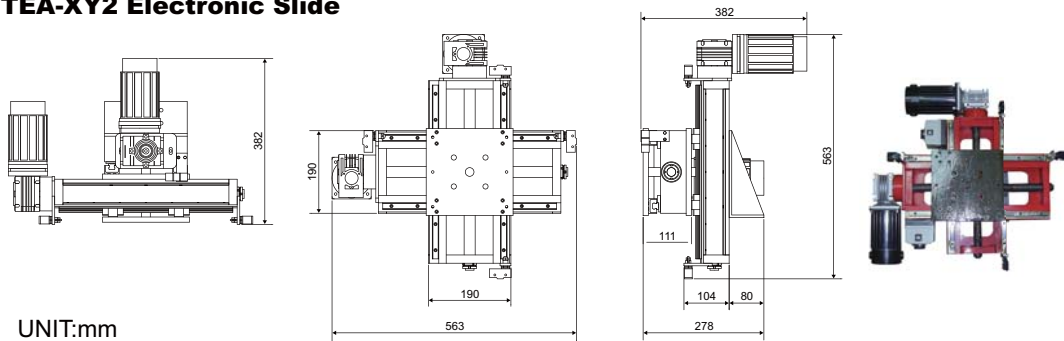

UNIT:mm

Power	AC 110V / 6A / 60Hz / 1Ø
Load	25Kgs.
LoadLevel stroke (X axle)	180mm.
Level speed	150mm/min
Vertical stroke (Y axle)	180mm.
Vertical speed	150mm/min
Control operation	Rocker



CONTROL PANEL

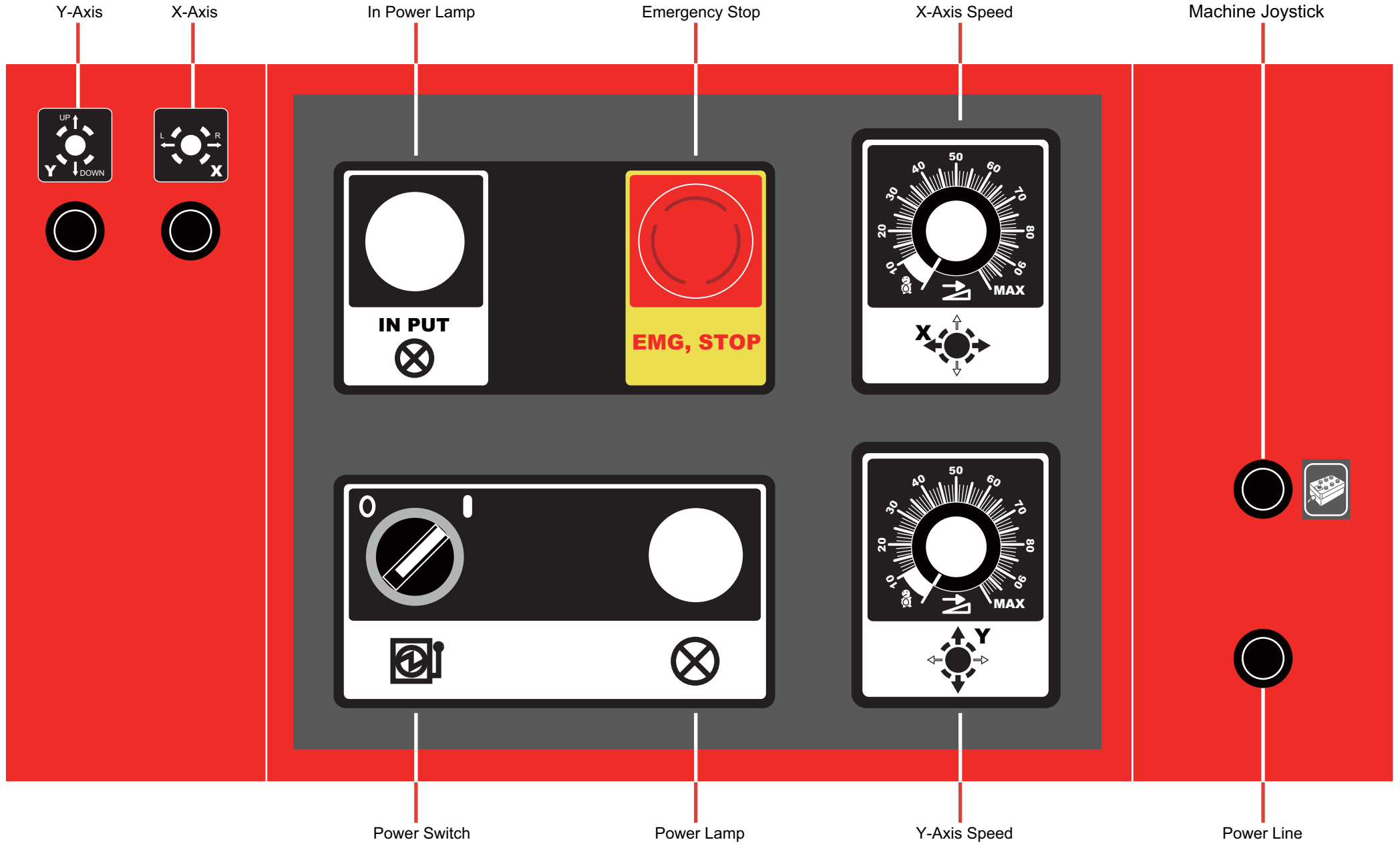

CONTROL BOX

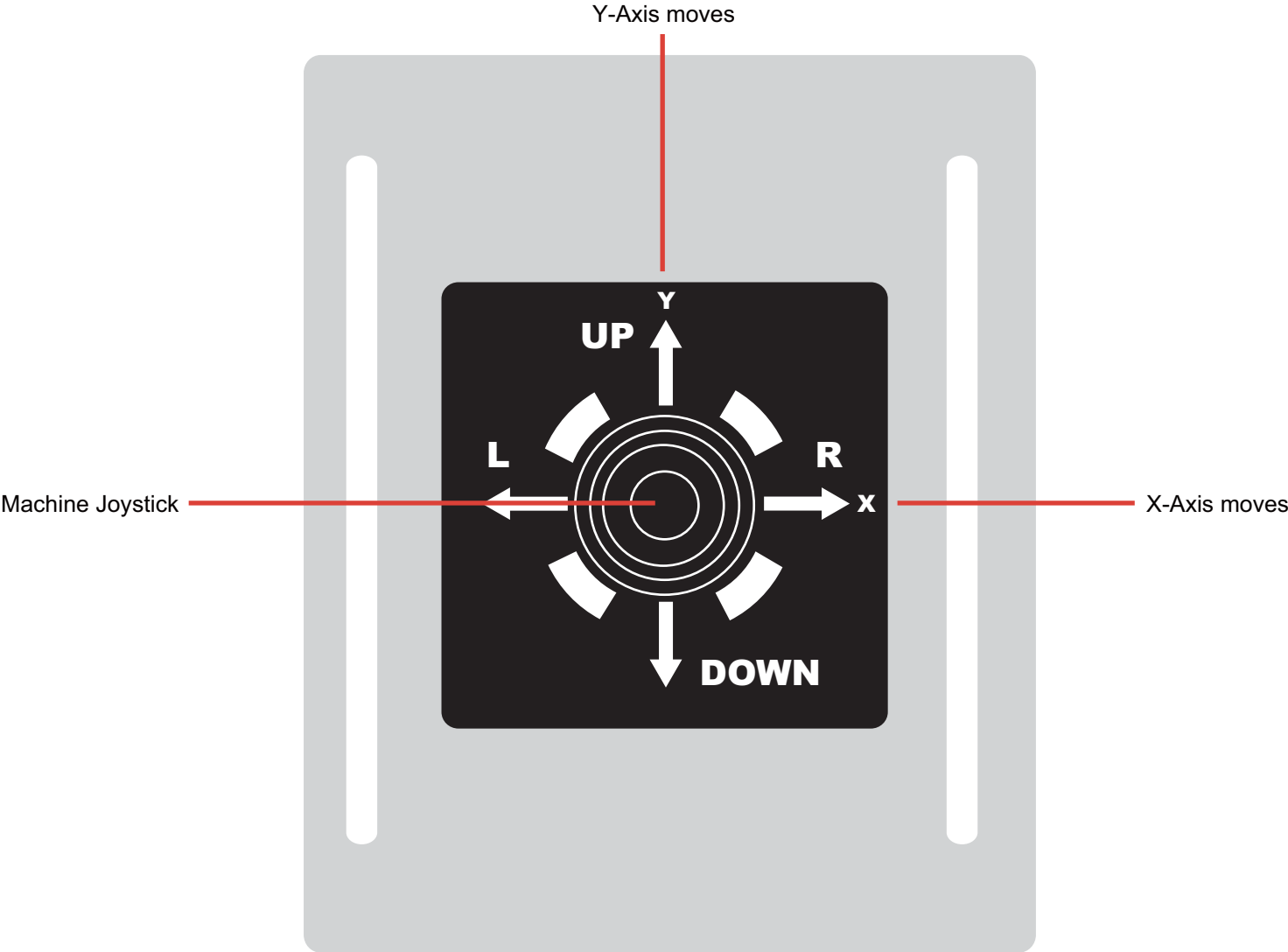

INSTALLER

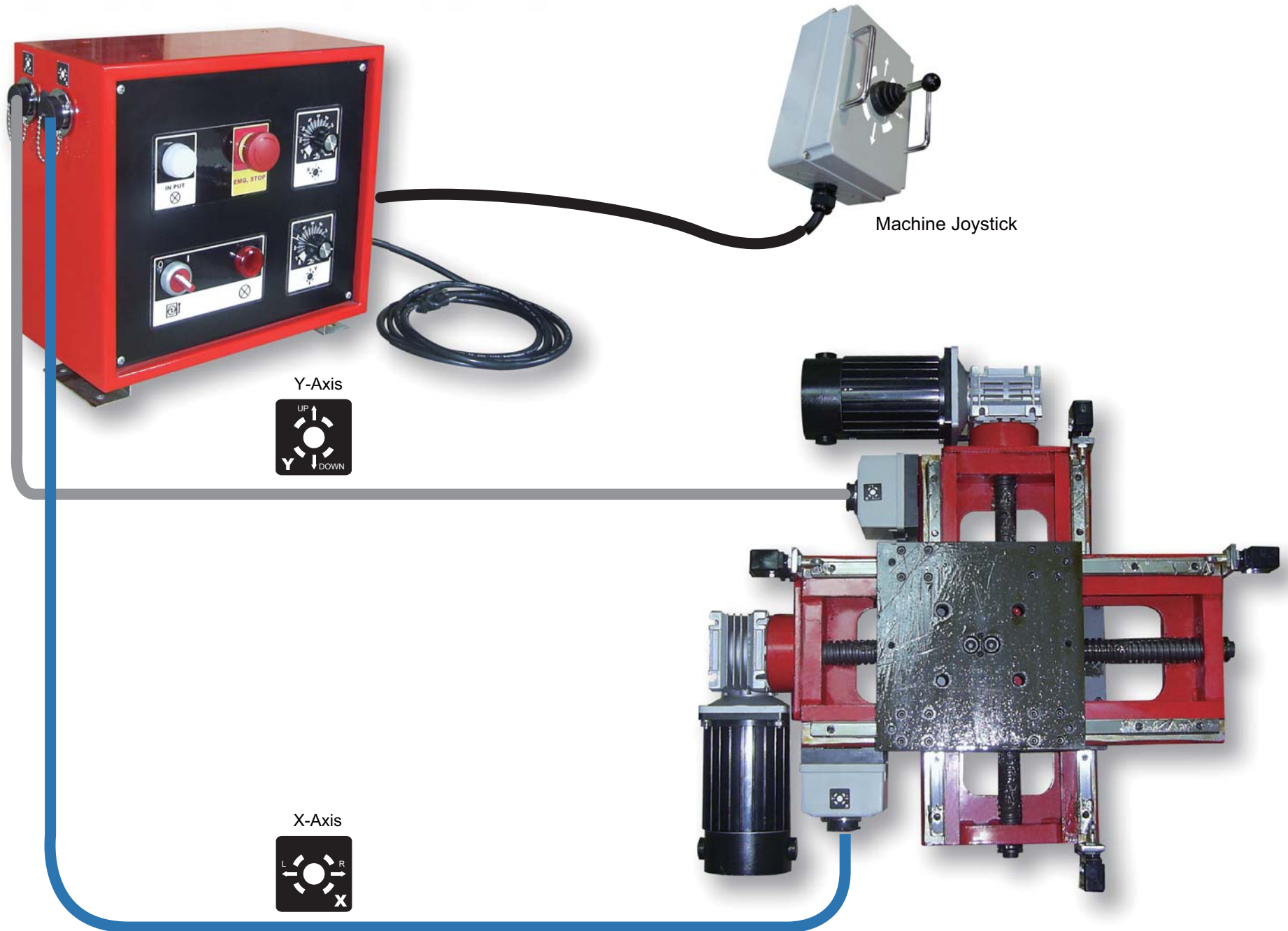

OPERATION

Y-Axis moves

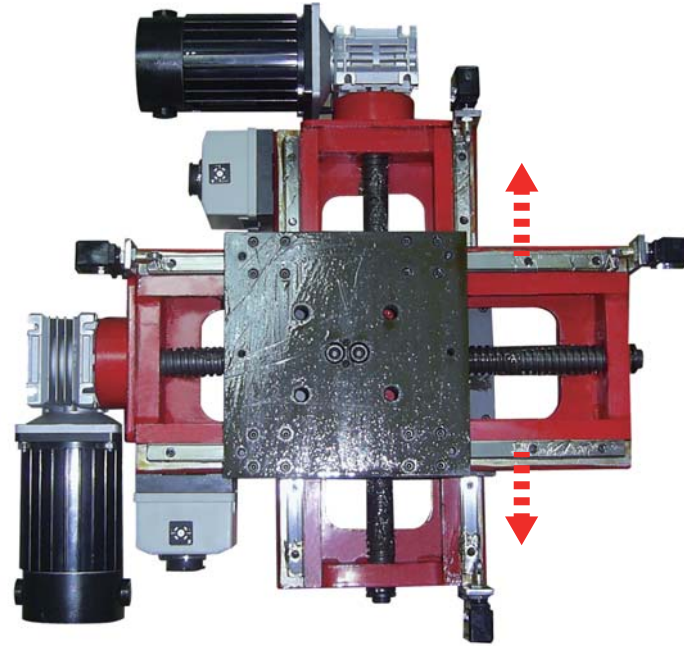
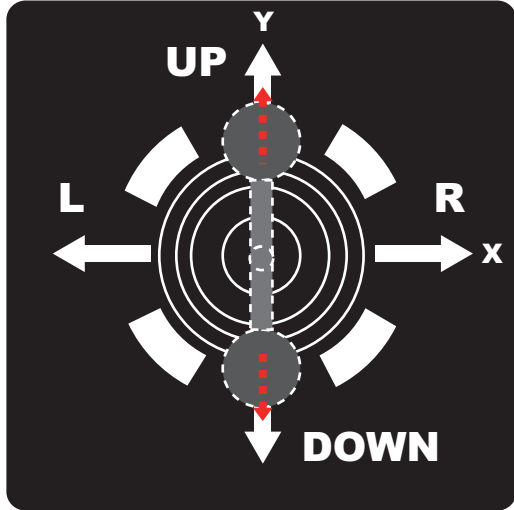

X-Axis moves

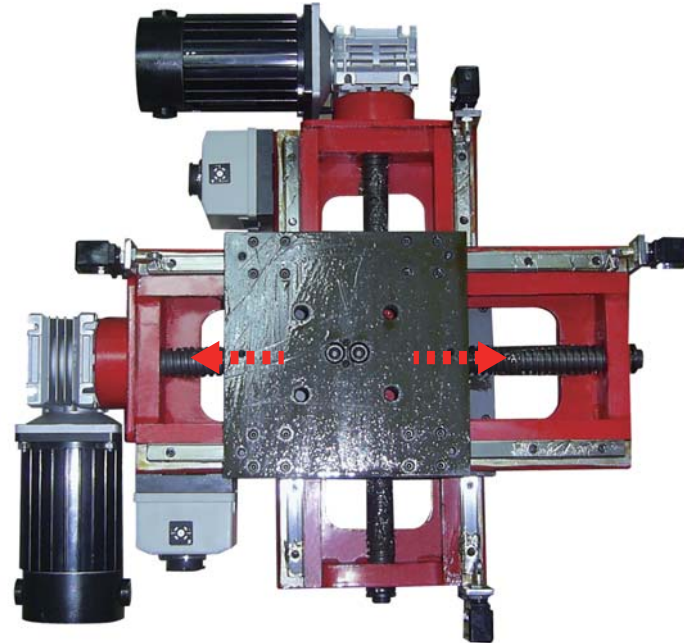
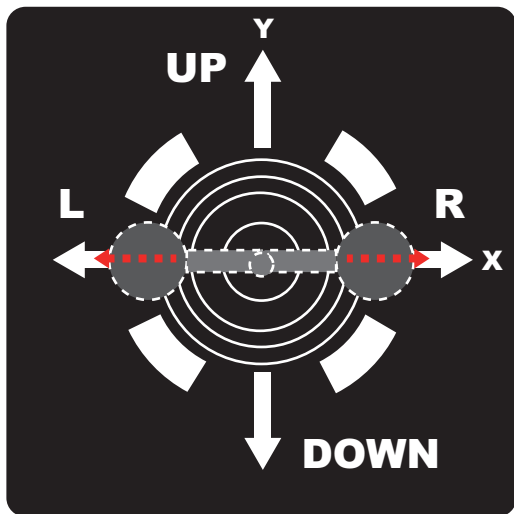

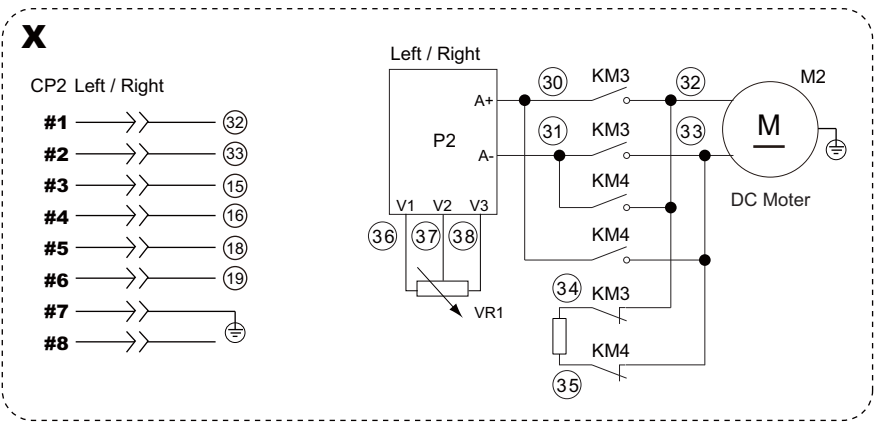
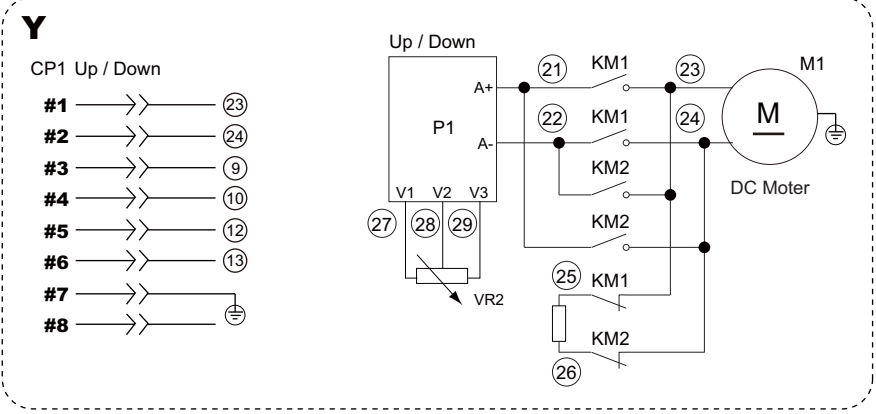
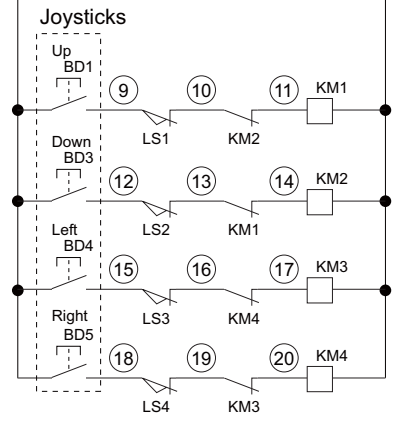
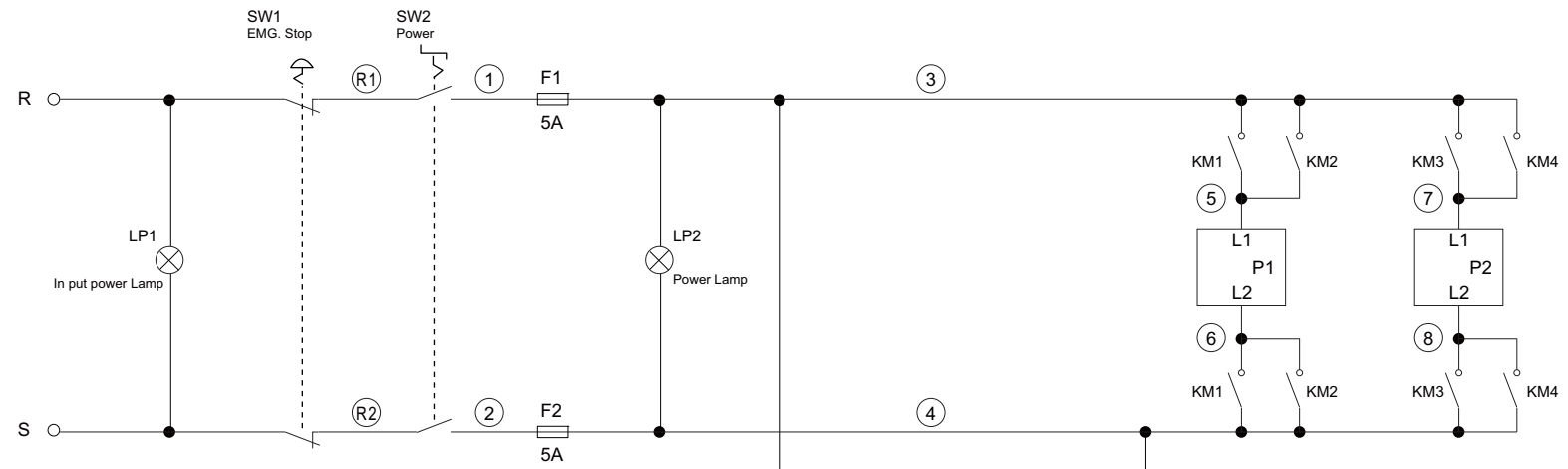

TEXY1 & TEXY2

AC 110V